

Tank Bottom Ball Valve

Features

- > The bottom ball valve is welded or flanged to the bottom of the reactor or tank and other containers by means of a valve bottom flange (flange). Therefore, the residual phenomenon of the process medium usually at the outlet of the container is eliminated, and the function of emptying and discharging is realized.
- > The bottom ball valve is composed of a valve body, a valve core, a valve stem, a valve seat, a sealing ring, an actuator (electric actuator, a pneumatic actuator) and the like.
- > The bottom ball valve principle is to push the valve flap up or down through the valve stem to achieve the purpose of opening and closing. The upper-opening tank bottom valve is that the valve stem is raised and the valve is opened; the lower-expanding tank bottom valve is that the valve stem is raised and the valve is closed.

Material List

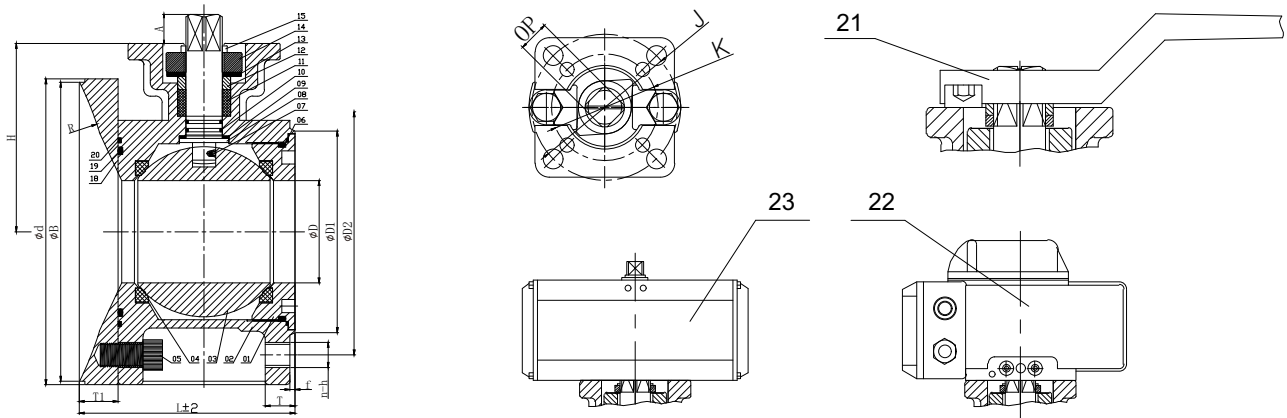

NO.	PARTS NAME	MATERIAL	MATERIAL
1	VALVE DECK	WCB	CF8
2	BODY	WCB	CF8
3	BALL	SS304	SS304
4	SEAT	PTFE	PTFE
5	BOLT	A193 B7	A193 B8
6	SEAL RING	PTFE	PTFE
7	Anti-Static	SS	SS
8	ROD	304	304
9	THRUST WASHER	PTFE	PTFE
10	O-RINR	NBR	NBR
11	PAICK	PTFE	PTFE
12	PAICK RING	SS	SS

NO.	PARTS NAME	MATERIAL	MATERIAL
13	Belleville Spring	SS	SS
14	PAICK GLAND	WCB	SS
15	Stop Block	SS	SS
16	Hexagon Bolt	A193 B7	A193 B8
17	NUT	A194 2H	A194 8
18	Arc Flange	A193 B7	A193 B8
19	O-RINR	A194 2H	A194 8
20	LING	SS	SS
21	Hand Shank	WCB	SS
22	Electric Actuator		
23	Pneumatic Actuator		

Tank Bottom Ball Valve

■ Features of Actuators

- > Heavy duty Rack and pinion design
- > Spring return or double acting
- > Open and closed adjustment stops
- > True NAMUR accessory and ISO mounting
- > Visual indicator, Top Mount indicator
- > High temperature and corrosion resistant models available
- > Solenoids, limit switches, positioners and other accessories are available

- > Fully adjustable limit switches allow for fine control of on-off positions
- > All electric actuators are available for modulating (4-20mA control) or on-off service
- > Motor has thermal overload protection
- > Running Time: 9s/13s/15s/30s/50s/100s/150s
- > Heavy-duty gear train motor with permanent lubrication
- > ISO bottom mounting for direct mount actuation with true ISO valves on most models



■ Dimensional Data

DN	PN	φD	φD1	φD2	φd	φB	n	h	T
25	16	25	68	85	115	111	4	M12	16
32	16	32	78	100	140	136	4	M16	18
40	16	38	88	110	150	146	4	M16	18
50	16	49	102	125	165	161	4	M16	20
65	16	62	122	145	185	179	4	M16	18
80	16	74	138	160	200	194	8	M16	20
100	16	100	158	180	220	214	8	M16	20

DN	T1	f	L	R	H	A	OP	φK	φJ
25	20	2	68	100	68	11	11	42	50
32	24	2	82	110	79	11	11	42	50
40	24	2	86	125	86	14	14	50	70
50	24	3	101	160	87	14	14	50	70
65	25	3	132	170	114	17	17	70	102
80	27	3	145	185	134	17	17	70	102
100	27	3	175	220	146	17	17	70	102

ALL VALVES ARE 100% ELECTRONICALLY TESTED AT 80 PSI IN BOTH THE OPEN AND CLOSED POSITIONS